

COBHAM

SAILOR 6204/6205 Control Speaker Microphone

User manual



SAILOR 6204/6205 Control Speaker Microphone

Document number: 98-133300-C

Release date: 22 October 2013

Copyright: © 2013 Thrane & Thrane A/S. All rights reserved.

Trademark Acknowledgements

- **Thrane & Thrane** is a registered trademark of Thrane & Thrane A/S in the European Union and the United States.
- **SAILOR** is a registered trademark of Thrane & Thrane A/S.
- **Other product and company names** mentioned in this manual may be trademarks or trade names of their respective owners.

Disclaimer

Any responsibility or liability for loss or damage in connection with the use of this product and the accompanying documentation is disclaimed by Thrane & Thrane A/S. The information in this manual is provided for information purposes only, is subject to change without notice and may contain errors or inaccuracies. Manuals issued by Thrane & Thrane A/S are periodically revised and updated. Anyone relying on this information should acquire the most current version e.g. from www.cobham.com/satcom or from the distributor. Thrane & Thrane A/S is not responsible for the content or accuracy of any translations or reproductions, in whole or in part, of this manual from any other source.

Thrane & Thrane A/S is trading as Cobham SATCOM.

Safety warning

The following general safety precautions must be observed during all phases of operation, service and repair of this equipment. Failure to comply with these precautions or with specific warnings elsewhere in this manual violates safety standards of design, manufacture and intended use of the equipment. Thrane & Thrane assumes no liability for the customer's failure to comply with these requirements.

Warranty limitation

IMPORTANT - The radio is a sealed waterproof unit (classified IPX8). To create and maintain its waterproof integrity it was assembled in a controlled environment using special equipment. The radio is not a user maintainable unit, and under no circumstances should the unit be opened except by authorized personnel. Unauthorized opening of the unit will invalidate the warranty.

Installation and service

Installation and general service must be done by skilled service personnel.

Emergency call for SAILOR 6204

Make sure your VHF Radio is on CH16



Use the CONTROL SPEAKER
MICROPHONE for voice calling

<p>MAYDAY-MAYDAY-MAYDAY This is NAME-NAME-NAME CALLSIGN or other IDENTIFICATION</p>	<p>OWN ID</p> <p>SHIP's NAME: _____</p> <p>CALLSIGN: _____</p>
---	---



<p>MAYDAY NAME of the VESSEL in distress CALLSIGN or other IDENTIFICATION POSITION given as latitude and longitude or If latitude and longitude are not known or if time is insufficient, in relation to a known geographical location NATURE of distress Kind of ASSISTANCE required Any other useful INFORMATION</p>

99-133823

Emergency call with Distress button for SAILOR 6205



Lift Cover

Press RED Button
until beep sounds continuously
(more than 3 seconds)



Use the CONTROL SPEAKER
MICROPHONE for voice calling

Make sure your VHF radio is on CH16

MAYDAY-MAYDAY-MAYDAY

This is

NAME-NAME-NAME

CALLSIGN

or other IDENTIFICATION

MMSI

(If the initial alert is sent by DSC)

OWN ID

SHIP's NAME: _ _ _ _ _

CALLSIGN: _ _ _ _ _

MMSI: _ _ _ _ _



MAYDAY

NAME of the VESSEL in distress
CALLSIGN or other IDENTIFICATION
MMSI

(If the initial alert is sent by DSC)

POSITION

given as latitude and longitude
or

If latitude and longitude are not known
or if time is insufficient,
in relation to a known geographical location

NATURE of distress

Kind of ASSISTANCE required

Any other useful INFORMATION

Manual Overview

This manual has the following chapters:

- *Introduction* contains a description of the Control Speaker Microphone.
- *Operation* explains how to work with the Control Speaker Microphone.
- *Installation* has dimensional drawings and other information useful when unpacking and installing the unit.
- *Service and maintenance* contains support and warranty information.

Related documents

Title and description	Document number
SAILOR 6222 VHF DSC User manual	98-131184
SAILOR 6248 VHF User manual	98-131186
SAILOR 6249 VHF Survival Craft User manual	98-133865
SAILOR 6000 VHF Program Installation manual	98-135548

Table of contents

Chapter 1 Introduction	
Overview	1
Controls	2
Display overview	3
Chapter 2 Operation	
Power on and general navigation	5
Button functions	6
Sending a Distress message (SAILOR 6205)	7
Chapter 3 Installation	
Unpacking	9
Initial inspection	9
What's in the box	9
Installing the Control Speaker Microphone	10
Dimensional drawing, with cradle	10
Drilling plan	11
Connector	12
Chapter 4 Service and maintenance	
Contact for support	13
Preventive maintenance	13
Warranty and returning units for repair	13
Repacking for shipment	14
App. A Technical specifications	
Control Speaker Microphone	15
Index	17

Introduction

Overview

The SAILOR 6204/05 Control Speaker Microphone (CSM) is a control and speaking device for remote radio operation of a VHF radio. The SAILOR 6204/6205 is powered by the radio and has full VHF radio functionality. The SAILOR 6205 has additionally class D DSC functionality.

CSM type	
MED	SAILOR 6204
R&TTE	SAILOR 6205

The Control Speaker Microphone is waterproof to the IPx8 and IPx6 standard.

The Control Speaker Microphone has a display with a view area of 40x30 mm and a menu-driven setup. The display can be dimmed for optimum readability and visibility (both day and night). Use the selector wheel and buttons to access the desired radio functions.

Up to four Control Speaker Microphones can be connected to one radio. If the radio requires the audio, the microphone of the Control Speaker Microphone is automatically switched off.



Controls

1. On/off and volume.
2. Dim display (short press), keyboard lock (long press).
3. Soft keys for radio operation.
4. Push To Talk button (PTT) to activate transmit mode.
5. Selector wheel to select a channel or soft key.
6. Shift key to switch between channel and soft key selection.
7. Replay button to play back recorded voice messages.
8. Squelch control to mute background noise.
9. 16/C quick selection key for channel 16 and the programmed call channel.
10. **Only** SAILOR 6205: Distress button on the rear.

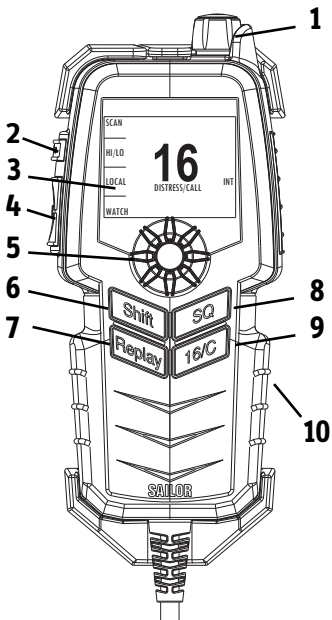

Display overview

The picture shows the display after start-up. The display holds various fields of information of the VHF radio, depending on the currently selected function.

Example for SAILOR 6204 and VHF radio

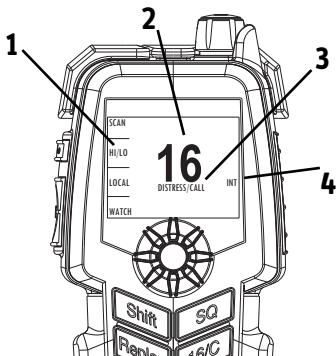

1. Soft-key functions of the radio.
2. Current working channel of the radio.
3. Service line containing temporary information relevant for the current channel or function.
4. Channel properties next to the currently selected VHF channel (if any) and current state of the radio (RX or TX).

Only SAILOR 6205: The position and MMSI number for the connected radio is shown in the DSC window (the lower half of the radio's display) in stand-by mode.

For a detailed description of each function available see the user manual of the radio.

Operation

Note

Before using the Control Speaker Microphone make sure it is correctly connected to the radio at the connector marked **CTRL** at the back of the radio or via a connection box. See the radio's installation manual for further information.

Power on and general navigation

1. **To power on**, press the knob at the top. The display lights up and shows the current display of the radio.
To power off, press down the knob at the top and follow the instructions given in the display.
2. **To transmit**, press the **PTT** button on the left side of the Control Speaker Microphone.
3. **To adjust the speaker volume** turn the knob at the top.
4. **To change the working channel or select a soft key function (Shift)**, turn the selector wheel. The soft key functions depend on the radio to which the Control Speaker Microphone is connected.

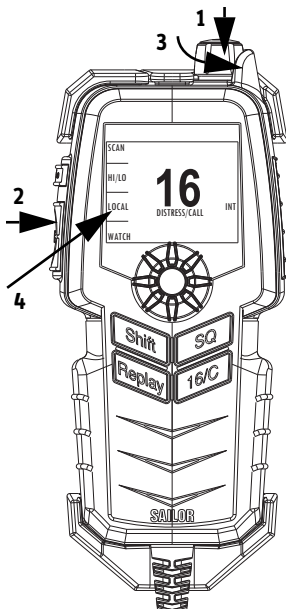

See the radio's user manual for further information.



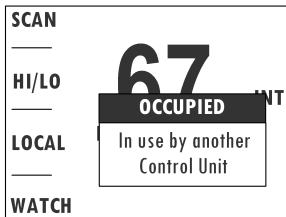

When operating the Control Speaker Microphone, the radio is occupied. When operating the radio, the Control Speaker Microphone is occupied. On the radio you can override the state of being occupied by pressing any key or lifting the handset.



Button functions

To dim the display backlight, make a short press on the Dim/lock button on the left side of the Control Speaker Microphone.

To lock/unlock the keys, make a long press on the Dim/lock button on the left side of the Control Speaker Microphone. To unlock the keys, repeat the key press.

Button	Function
	To switch between channel and soft key selection.
	To replay messages recorded by the radio.
	To adjust squelch. Adjust the squelch level by turning the selector wheel. Press the key SQ again or wait for time-out to return to normal operation.
	A single, short press on the 16/C key always brings you to channel 16 , the international calling and Distress channel, no matter what state the Control Speaker Microphone or the radio is in.

Sending a Distress message (SAILOR 6205)

1. Lift the cover of the red Distress button at the rear of the SAILOR 6205 and press and hold the distress button for longer than 3 seconds. For short step-by-step instructions how to proceed when sending a distress message see *Emergency call with Distress button for SAILOR 6205* on page iv.



When the distress signal is sent, **CH70** and **Tx** appear in the display. A two-seconds steady tone is heard from the radio.

ANNUL	OWN DISTRESS
—	WAIT FOR ACK
INFO	ELAPSED TIME 0:00:10
—	—
PAUSE(ACTIVE)	—
—	REPEAT IN 2:11
MORE	CH: 16

2. The radio watches for a DSC acknowledgement transmission on channel 70.
3. To pause the automatic resend procedure press the shift key, turn the selector wheel and press OK on **PAUSE**.
4. To annul the distress message press the soft key **ANNUL**. For further details see the user manual of the connected radio.
5. When a distress acknowledgement is received, a pop-up window is displayed. Start distress communication on channel 16 to inform about your distress situation.

Note

If no distress acknowledgement is received within a period of 3,5 to 4,5 minutes, the distress message will automatically be retransmitted.

Having pressed the red distress button and sent the distress message, the following information is displayed:

- STATION: shows the radio's MMSI number.
- NAT: shows the nature of distress.
- LAT:, LON:, POS UTC: shows the distress position data as transmitted.
- MODE: shows the communication mode.
- Elapsed time after initiation of own distress.
- Time to next repeat of sending own distress.

If you sent a distress message, the VHF radio is automatically set to channel 16, the channel reserved for international distress, safety and calling.

See the radio's user manual for further details.

Installation

Unpacking

Initial inspection

Inspect the shipping carton immediately upon receipt for evidence of damage during transport. If the shipping carton is severely damaged or water stained, request that the carrier's agent be present when opening the carton. Save the carton packing material for future use.



To avoid electric shock, do not apply power to the system if there is any sign of shipping damage to any part of the front or rear panel or the outer cover. Read the safety summary at the front of this manual before installing or operating the system.

After unpacking the system, inspect it thoroughly for hidden damage and loose components or fittings. If the contents are incomplete, if there is mechanical damage or defect, or if the system does not work properly, notify your dealer.

What's in the box

- Control Speaker Microphone with spiral cable and connector
- Cradle for Control Speaker Microphone
- User manual (this manual)
- 5 m extension cable with connector
- Kit with mounting screws

Installing the Control Speaker Microphone

Dimensional drawing, with cradle

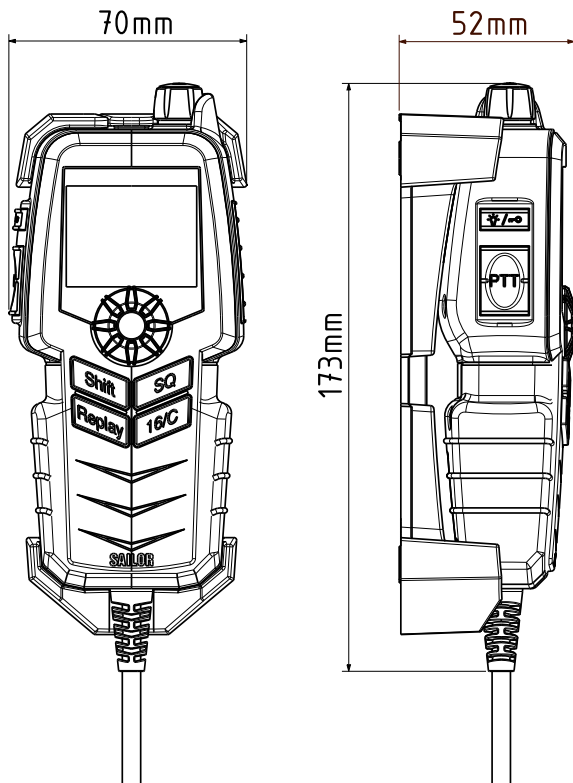

Drilling plan

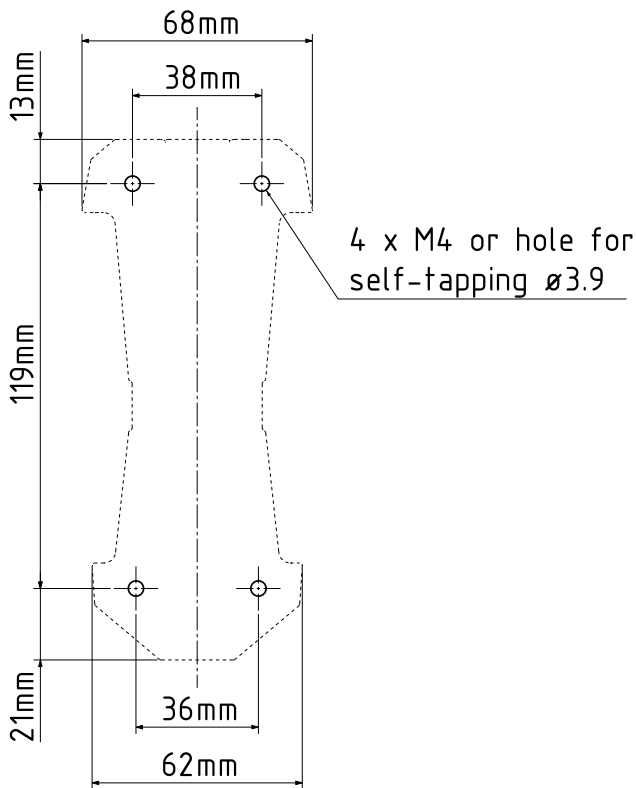

Connector

Connector type: Circular connector, 12 pin.

Pin assignment: Connector front view on the VHF radio:

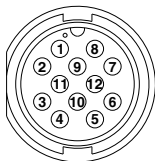

Pin	Description	Wire color
1	GND for cable screen	Brown
2	Internal GND=- Battery	Blue
3	Battery supply when radio is on	White
4	Battery supply when radio is on	Green
5	CAN+	Yellow
6	CAN-	Grey
7	Internal GND = - Battery	Pink
8	On/off from Control Speaker Microphone	Red
9	RX out +	Black
10	RX out -	Orange
11	TX in +	Violet
12	TX in -	Cyan

Connecting several Control Speaker Microphones

For instructions how to connect several Control Speaker Microphones see the system configuration examples in the radio's installation manual.

Service and maintenance

Contact for support

Contact your authorized dealer for technical service and support of the Control Speaker Microphone.

Preventive maintenance

Maintenance of the Control Speaker Microphone can be reduced to a maintenance check at each visit of the service staff. Inspect it for mechanical damages, salt deposits, corrosion and any foreign material. Due to its robust construction and ruggedness the Control Speaker Microphone has a long lifetime. Anyway it must carefully be checked at intervals not longer than 12 months - dependent on the current working conditions.

Warranty and returning units for repair

Should your Cobham SATCOM product fail, please contact your dealer or installer, or the nearest Cobham SATCOM partner. You will find the partner details on www.cobham.com/satcom where you also find the Cobham SATCOM Self Service Center web-portal, which may help you solve the problem.

Your dealer, installer or Cobham SATCOM partner will assist you whether the need is user training, technical support, arranging on-site repair or sending the product for repair.

Your dealer, installer or Cobham SATCOM partner will also take care of any warranty issue.

Repacking for shipment

Should you need to send the product for repair, please read the below information before packing the product.

The shipping carton has been carefully designed to protect the Control Speaker Microphone and its accessories during shipment. This carton and its associated packing material should be used when repacking for shipment. Attach a tag indicating the type of service required, return address, part number and full serial number. Mark the carton FRAGILE to ensure careful handling.

Note

| Correct shipment is the customer's own responsibility.

If the original shipping carton is not available, the following general instructions should be used for repacking with commercially available material.

1. Wrap the defective unit in heavy paper or plastic. Attach a tag indicating the type of service required, return address, part number and full serial number.
2. Use a strong shipping container, e.g. a double walled carton.
3. Protect the front- and rear panel with cardboard and insert a layer of shock-absorbing material between all surfaces of the equipment and the sides of the container.
4. Seal the shipping container securely.
5. Mark the shipping container FRAGILE to ensure careful handling. Failure to do so may invalidate the warranty.

Technical specifications

Control Speaker Microphone

Item	Specification
Weight Control Speaker Microphone	320 g (0.7 lbs)
Box weight	1.2 kg (2.6 lbs) approximately, including wall mount cradle, cable and Installation and user manual in box.
Dimensions	Height: 173 mm Width: 70 mm Depth: 52 mm, including front selector wheel and cradle
Operating temperature	-25°C to 55°C (5°F to 131°F)
Storage temperature	-30°C to 80°C (-22°F to 176°F)
Power supply	Powered by the radio.
Current consumption	Powered by the radio.

For more specifications see the radio's installation manual.

Numerics

16/C, 2, 6

A

accessories included, 9
approvals, 1

C

connect
 several CSMs, 12
connector
 CTRL, 12
 pin assignment, 12
contact, 13
CTRL connector, 12

D

delivery, items included, 9
dim, 2, 6
dimensions, 10
Distress
 button, 7
 channel, 6
 display, 8
 time since activation, 8
Distress message
 send, 7
drilling plan, 11

E

emergency call procedure, iii
 DSC, iv
extension cable, 9

I

installation, 9

K

key
 16/C, 6
 replay, 6
 Shift, 6
 squelch, 6

L

lock, 6

M

mounting screws, 11

P

pin assignment, 12
power
 off, 5
 on, 5
PTT, 2

R

repacking for shipment, 14

replay, 2, 6

S

safety warning, ii

salt deposits, 13

screws, 11

Shift key, 6

soft key

 function, 5

 selection, 6

speaker volume, 5

specifications, 15

squelch, 2

 key, 6

support, 13

T

technical data, 15

temperature

 operational, 15

 storage, 15

U

unlock, 6

W

warranty, 13

weight, 15

98-133300-C

www.cobham.com/satcom

COBHAM